

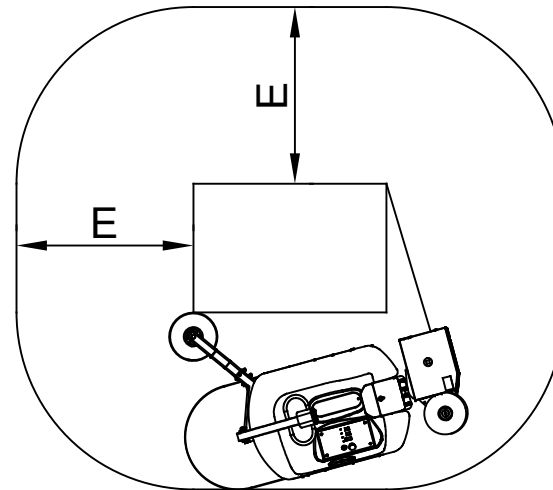

DIMENSIONI MACCHINA / MACHINE DIMENSIONS					
H(mm)	1800	2200	2700	3000	3500
A(mm)	1915	2315	2815	3115	3615
B(mm)	1165	1165	1165	1165	1190
C(mm)	1765	1765	1765	1765	1765
D(mm)	1670	2070	2570	2870	3370
E(mm)	1100	1100	1100	1100	1400

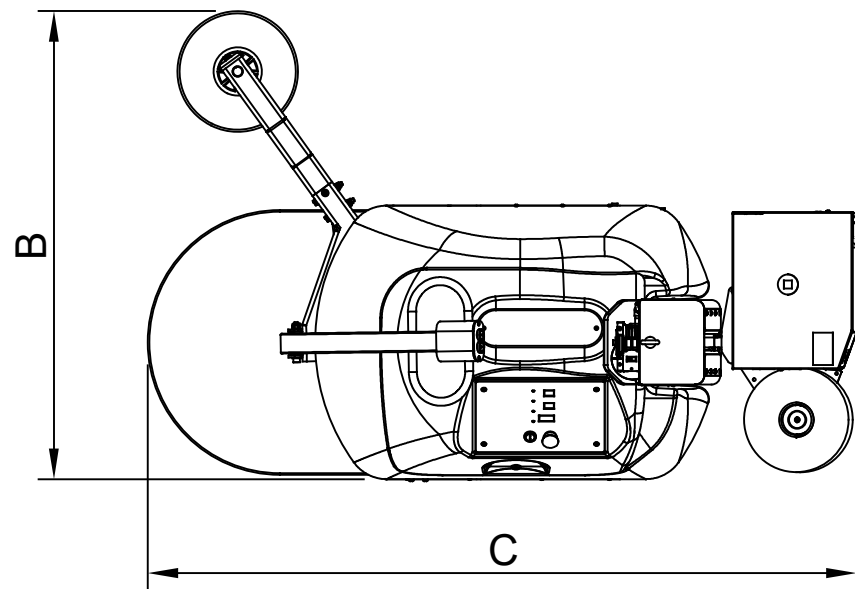

Wrapping
product
dimensions

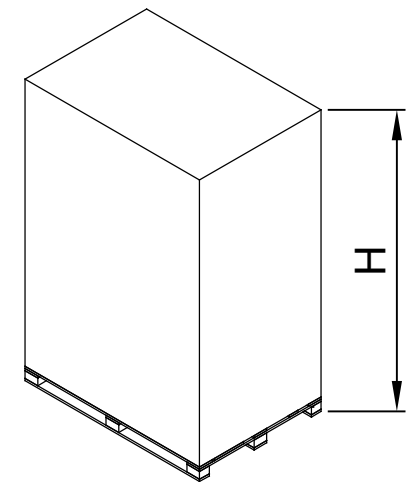

DIS. / Draft man	DATA / Date	F.to/Size A3	FOGLIO/Sheet 1 of 1	SCALA/Scale 1:25	SDST. IL /Sub. by	SIMILE A /Same to		
RACCORDI NON QUOTATI Not dimensioned fillets		R=0.8	SPUNSI NON QUOTATI Not dimensioned bevels	0.5x45°	NOTE SENZA INDICAZIONE DI TOLLERANZA Measures (unspecified tolerances) UNI ISO2768	TIPO PARTE C.O.	TATTAMENTI TERMICI / Thermal treatments	
 MEDIAPAC® IL VOSTRO PARTNER PER L'IMBALLAGGIO						DENOMINAZIONE PARTICOLARE / Description Part		PESO/Weight
						DIMENSIONI ROBOT SFERA PALO		Kg
DOCUMENTO RISERVATO A TERMINI DI LEGGE CON DIVIETO DI RIPRODUZIONE O DI RENDERLO COMUNQUE NOTO A TERZI SENZA ESPlicita AUTORIZZAZIONE						CODICE DISEGNO / Drawing code		REV.